



Republic of the Philippines
Department of Agriculture
Bureau of Fisheries and Aquatic Resources

BIDS AND AWARDS COMMITTEE OFFICE

3/F PCA Bldg., Elliptical Road, Diliman, Quezon City, Philippines 1101
Tel. No.: +02. 332. 4661 website: www.bfar.da.gov.ph /e-mail: bfarbac2018@gmail.com

SUPPLEMENTAL BID BULLETIN 01

April 26, 2021

SUBJECT : Bid Reference 2021-13 entitled "SUPPLY AND DELIVERY OF FIBERGLASS-REINFORCED PLASTIC (FRP) SUPPLIES AND MATERIALS, FABRICATION TOOLS AND ACCESSORIES, UNDERWATER FITTINGS, MARINE ENGINES AND 4DR5 WITH TRANSMISSION FOR THE CONSTRUCTION OF FRP BOATS."

This Supplemental Bid Bulletin no. 1 is issued to all participating bidders to clarify, amend and/or modify certain provisions and requirements set forth under the above-entitled procurement project based on the result of the Pre-bid Conference conducted on April 20, 2021, 10:00 a.m. to wit:

• **Section III – Bid Data Sheet**

FROM	TO
ITB Clause 5.3 For this purpose, contracts similar to the Project shall be: a. SUPPLY AND DELIVERY OF FIBERGLASS-REINFORCED PLASTIC (FRP) SUPPLIES AND MATERIALS, FABRICATION TOOLS AND ACCESSORIES, UNDERWATER FITTINGS, MARINE ENGINES AND 4DR5 WITH TRANSMISSION FOR THE CONSTRUCTION OF FRP BOATS.	ITB Clause 5.3 For this purpose, contracts similar to the Project shall be: Lot 1: SUPPLY AND DELIVERY OF FIBERGLASS-REINFORCED PLASTIC (FRP) SUPPLIES AND MATERIALS FOR THE CONSTRUCTION OF FRP BOATS. Lot 2: SUPPLY AND DELIVERY OF FABRICATION TOOLS AND ACCESSORIES FOR THE CONSTRUCTION OF FRP BOATS. Lot 3: SUPPLY AND DELIVERY OF UNDERWATER FITTINGS FOR THE CONSTRUCTION OF FRP BOATS. Lot 4: SUPPLY AND DELIVERY OF MARINE ENGINES. Lot 5: SUPPLY AND DELIVERY OF 4DR5 WITH TRANSMISSION.

- Section VII - Technical Specifications

1. Lot 3. UNDERWATER FITTINGS 15-footer	
FROM	TO
Stainless rudder assembly 5/8" x 3' (plate size: 8"x10")	Stainless rudder assembly 5/8" x 3' (plate size: 6"x 8")
2. Lot 3. UNDERWATER FITTINGS 38-footer	
FROM	TO
Propeller 2 blades 17"x 18"	Propeller 2 blades 18" x 1 1/4"
Rudder Assembly 12" x 1 1/4", plate size 12"x14"	Rudder Assembly 1 1/4"Ø x 5' plate size 12"x14"
3. Lot 4. MARINE ENGINES 5.5 HP	
FROM	TO
Maximum Power: 5.5hp/3600rpm	Maximum Power: 5.5hp/3600rpm
Fuel Tank Capacity: 4.11 L	Fuel Tank Capacity: 3.6 L

LOT NO. 3 - TECHNICAL DRAWING OF THE 15-FOOTER UNDERWATER FITTINGS

Rudder Assembly

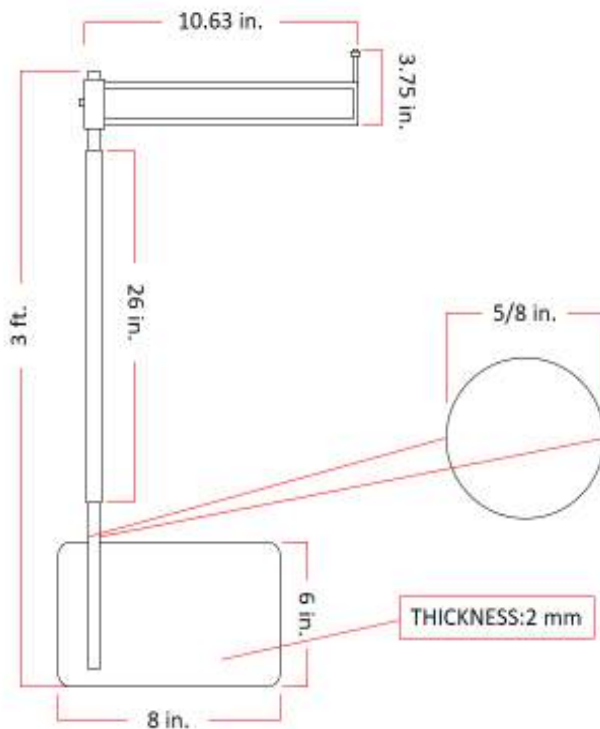

Stainless Shaft and Brass Pipe

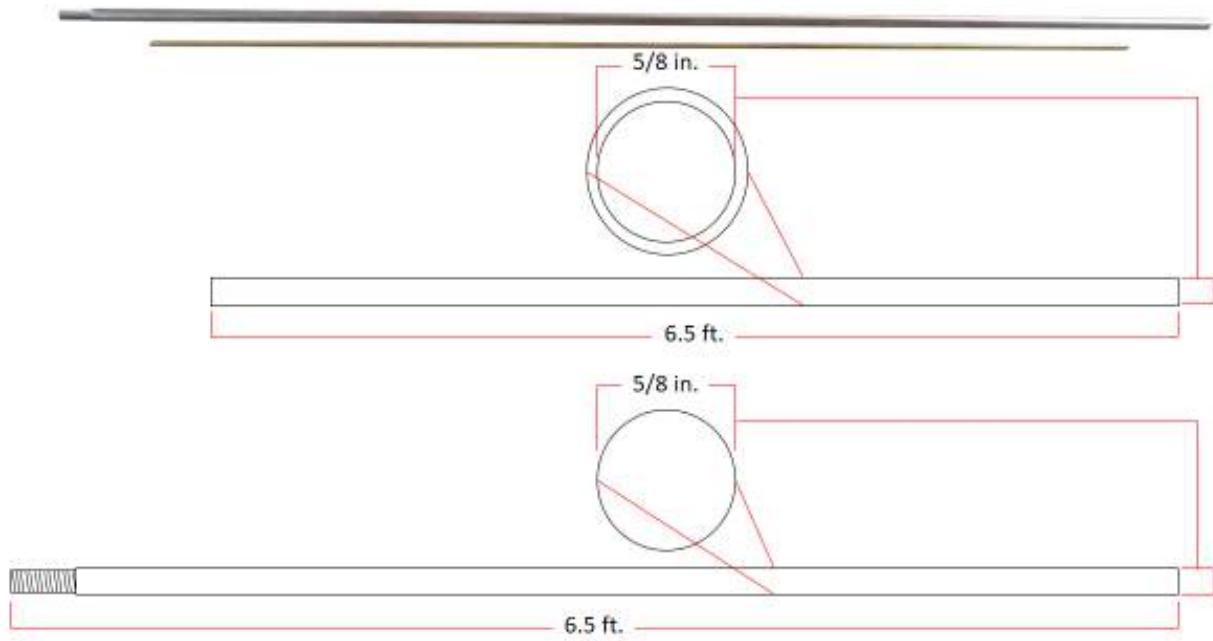

A/S flex (Crossjoint)

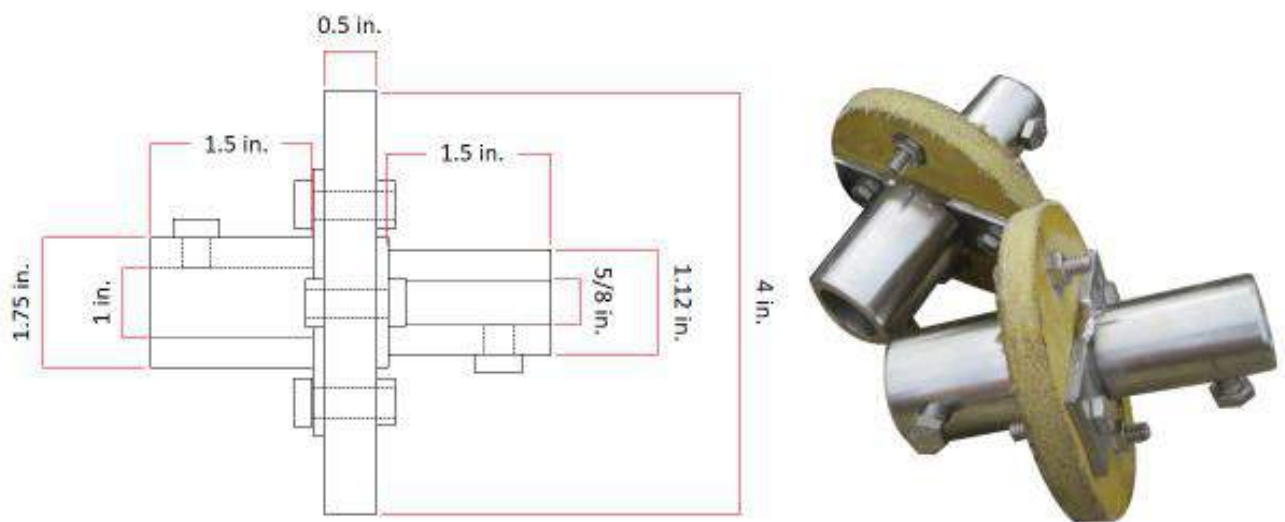

Stainless Propeller

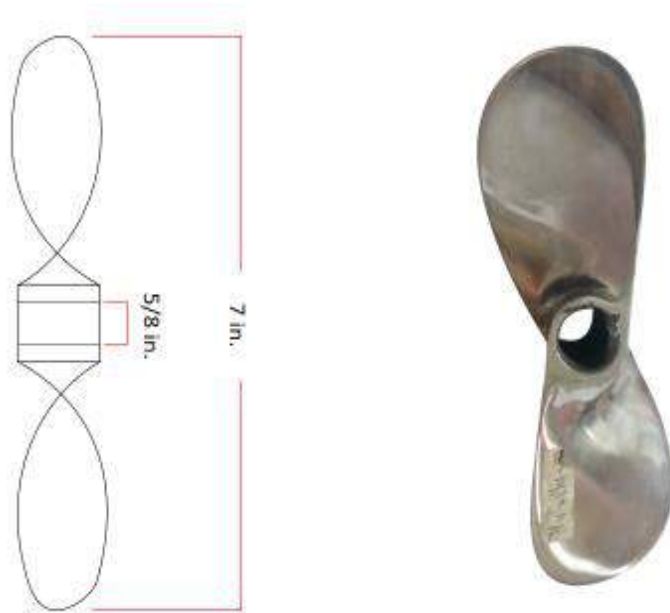

TECHNICAL DRAWING OF THE 38-FOOTER UNDERWATER FITTINGS

BALL JOINT 1 1/2" x 1 1/4"

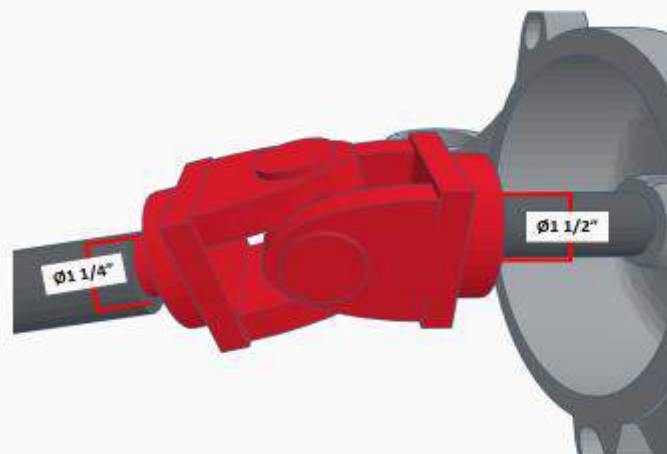

PROPELLER SHAFT 1 ¼"x20'

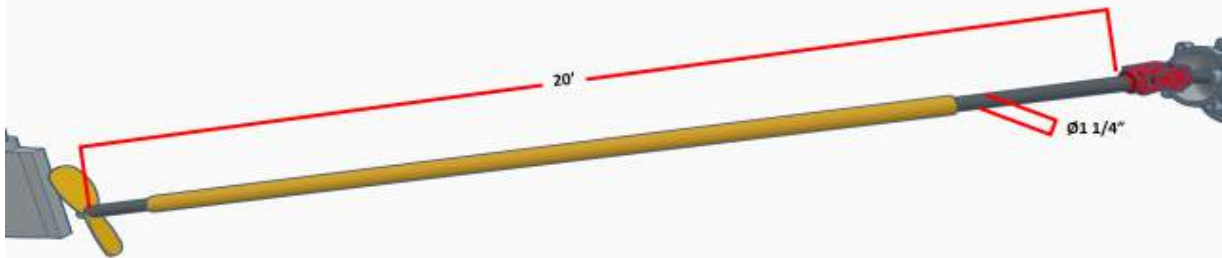

BUSHING (BRASS PIPE) 1 ¼"x8'

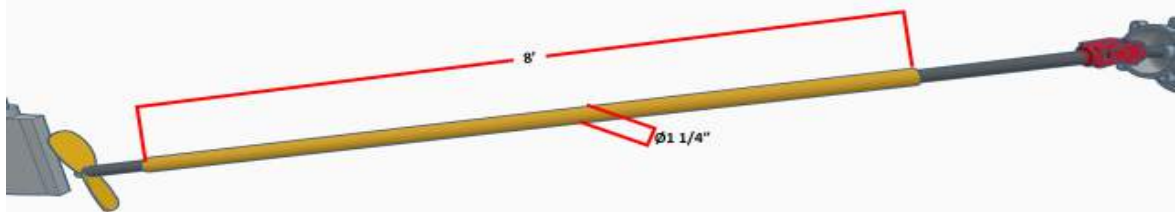

PROPELLER 2 BLADE 18" x 1 1/4"

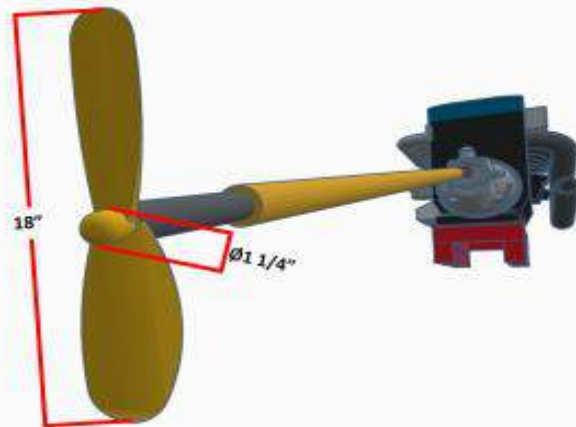

RUDDER ASSEMBLY 1 1/4" x 5' PLATE SIZE 12" x 14"

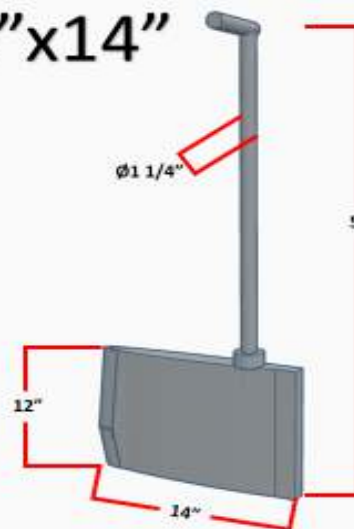

*****nothing follows*****

All other portions of the Bidding Documents affected by these amendments shall be made to conform the same.

Amendments/inclusions/clarifications made herein shall be considered an integral part of the Bidding Documents.

The changes made in the Philippine Bidding Documents (6th Edition, July 2020) are deemed integrated in terms and conditions for this project.

For further inquiries, please coordinate/call the Bids and Awards Committee Secretariat at Tel. No. 8332-4661.

Please be guided accordingly.

Original Signed

ATTY. DEMOSTHENES R. ESCOTO

Chairman, Bids and Awards Committee